

G9 HIGH EFFICIENCY GAS HEATER

MORE FOR LESS

Use less energy and heat your pool and spa faster with Australia's only high efficiency gas pool and spa heater. With a net efficiency of up to 95% the G9 heater range reduces gas consumption and emissions by more than 20% over minimum efficiency pool and spa heaters. Flue gases are so cool that they turn into water which is mechanically eliminated by the inbuilt condensate pump.



WHY CHOOSE THE G9 GAS HEATER?

ON DEMAND SWIMMING

A gas pool and spa heater has the capacity and energy to heat your pool fast. So fast in fact, that it does not have to be left on all the time. Fancy a swim this weekend? Turn your gas heater on Friday night or Saturday morning to achieve idyllic water temperature over the weekend, then simply turn it off on Sunday night. Have the impulse to use your spa? A correctly sized gas heater can heat your spa in an hour or less. Only gas can be turned on and off to suit your swimming or spa bathing needs, heating on demand and reducing your energy bills.

EFFICIENT USE OF ENERGY AND LOWER EMISSIONS

Insnr's next level ceramic fibre burner produces clean combustion and the highly efficient double row cupro nickel heat exchanger absorbs nearly all of this heat to emit very low flue gas temperature. Compared to conventional minimum efficiency gas pool heaters, the G9 saves 20% on gas consumption and reduces CO2 emissions. In other words the energy produced by the premixed combustion system is absorbed into the pool and spa water to heat faster with less energy consumption.

COMPACT SIZE

The G9 gas heater has one of the smallest footprints reducing the valuable real estate taken by your pool equipment.

DURABLE

Made from long life recyclable plastics, stainless steel internals and high grade components, Insnr's G9 Gas Heater will last for years providing trouble free enjoyment and pleasure in your pool or spa.

ENGINEERED FOR LONG LIFE

Carefully selected and designed materials are used throughout the G9 heater.

- Stainless Steel combustion chamber carefully selected to equalise expansion and contraction from heating
- Stainless Steel CNC machined tube plates minimises corrosion
- Bimetallic and cupro nickel extruded finned tube heat exchanger
- EC brushless DC high efficiency combustion blower
- Positive displacement pumps eliminates condensate produced from low flue gas temperature
- Heavy duty reinforced water manifolds incorporate an automatic temperature control valve to ensure ideal water flow through heat exchanger.
- Electronically controlled pre mixed air and gas ratios combine for clean combustion, low NOx and other emissions.
- Premium combustion insulation with low bio persistence and thermal conductivity
- Unique ceramic fibre burner that eliminates rust and corrosion

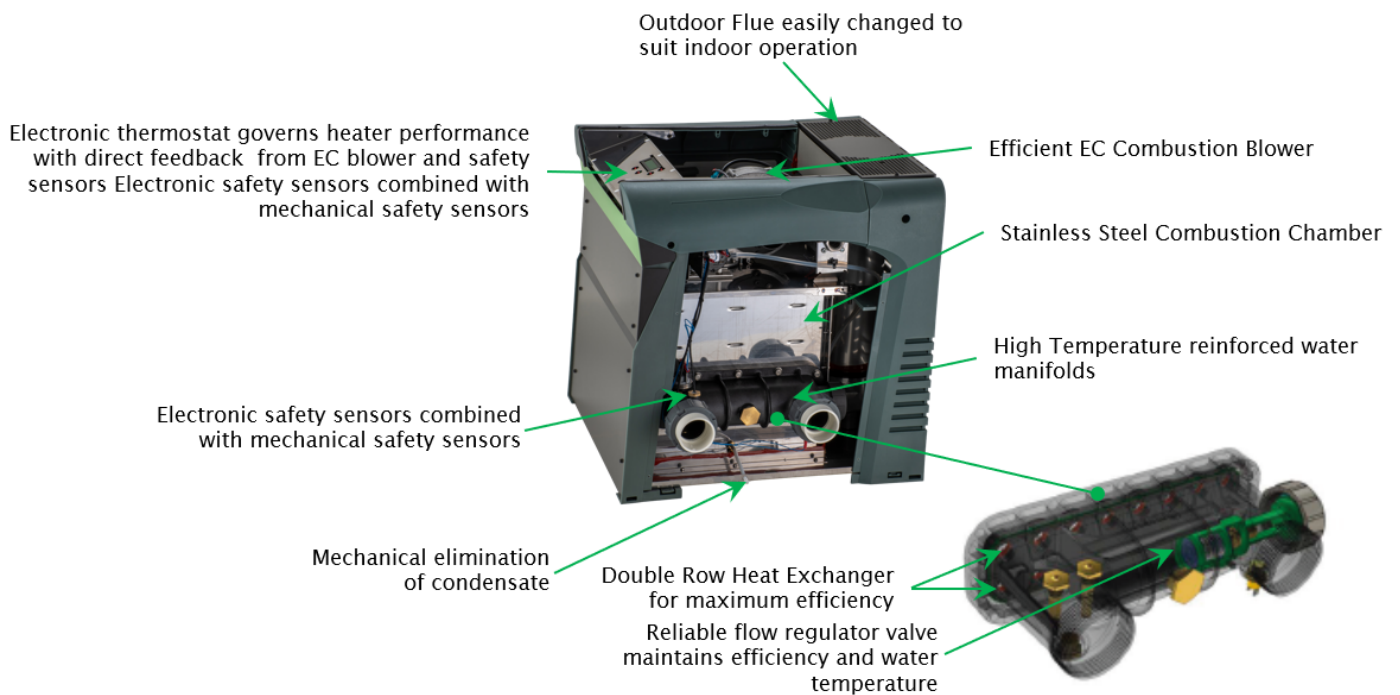

FAST HEAT UP - WAIT LESS, SPEND MORE TIME SWIMMING

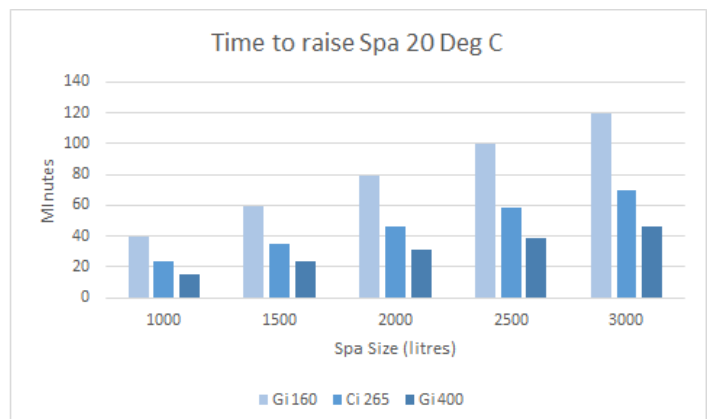
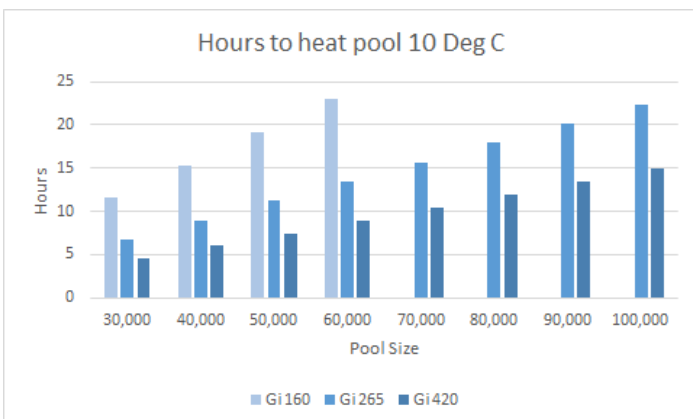

AUTOMATION INTEGRATION

The G9 Heater is ideally paired with Insrng's Vi Automation System which allows total control of your pool, spa, water temperature, motorised valves, water features and pool lights.

When installed with the inTouch Portal and Vi Automation System, the G9 communicates water temperature, heating status, service status and gives you full control of your pool and spa water temperatures. Insrng's whole suite of products are seamlessly controlled with the inTouch Portal.



MONITOR-CONTROL-SCHEDULE

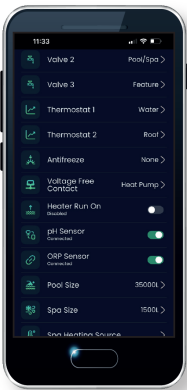

Adding the inTouch Wi-Fi Portal enables complete set up and programming of your pool and spa operating system from your phone, tablet or computer. Assign pumps, water features, motorised valves, temperature sensors, pool size and type and the system automatically recommends water balance settings, pump speeds and heating priorities.

Edit your home screen and rename appliances to suit your special pool and viewing at a glance.

Start your spa with the touch of an icon and monitor the heating progress.

Observe the system status and water temperature graph and solar contribution each day.

Use the invitation function to allow full or limited access by friends, family or guests.

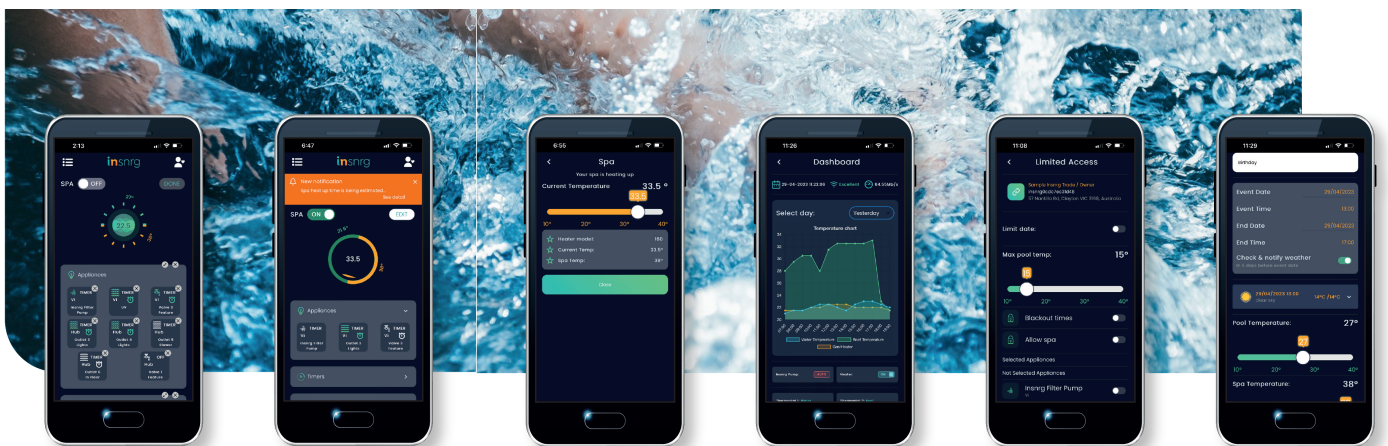

Plan pool parties weeks in advance and inTouch will automatically calculate when to turn appliances on to heat, filter, and light your pool to the perfect pool party temperature. Not only convenient but reduces operating costs by turning on precisely when needed.

The inTouch Automation will even perform a routine diagnostic check to ensure everything is operating correctly when you plan your event.

GET EXPERT HELP

inTouch even allows you to invite your trusted pool technician to remotely access your pool system to see data and monitor your equipment performance and pool water quality. Need help? Your pool tech is only a phone call away with the remote access capability.

SPACE IS EXPENSIVE

Space is at a premium and the G9 has the smallest footprint of all today's gas pool heaters. It has the lowest profile and has minimal clearances saving your valuable real estate.

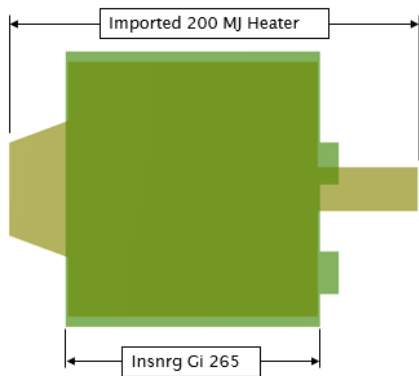

SPECIFICATIONS

MODEL	G9 160	G9 265	G9 420
INPUT (MJ/h)	140	230	370
OUTPUT (kW/h)	38	63	90
EFFICIENCY	>90%	>90%	>90%
LEFT OR RIGHT HAND WATER CONNECTIONS	YES	YES	YES
WIDTH 'A' (mm)	495	605	765
WIDTH 'A' (in)	19.5	23.8	30.1

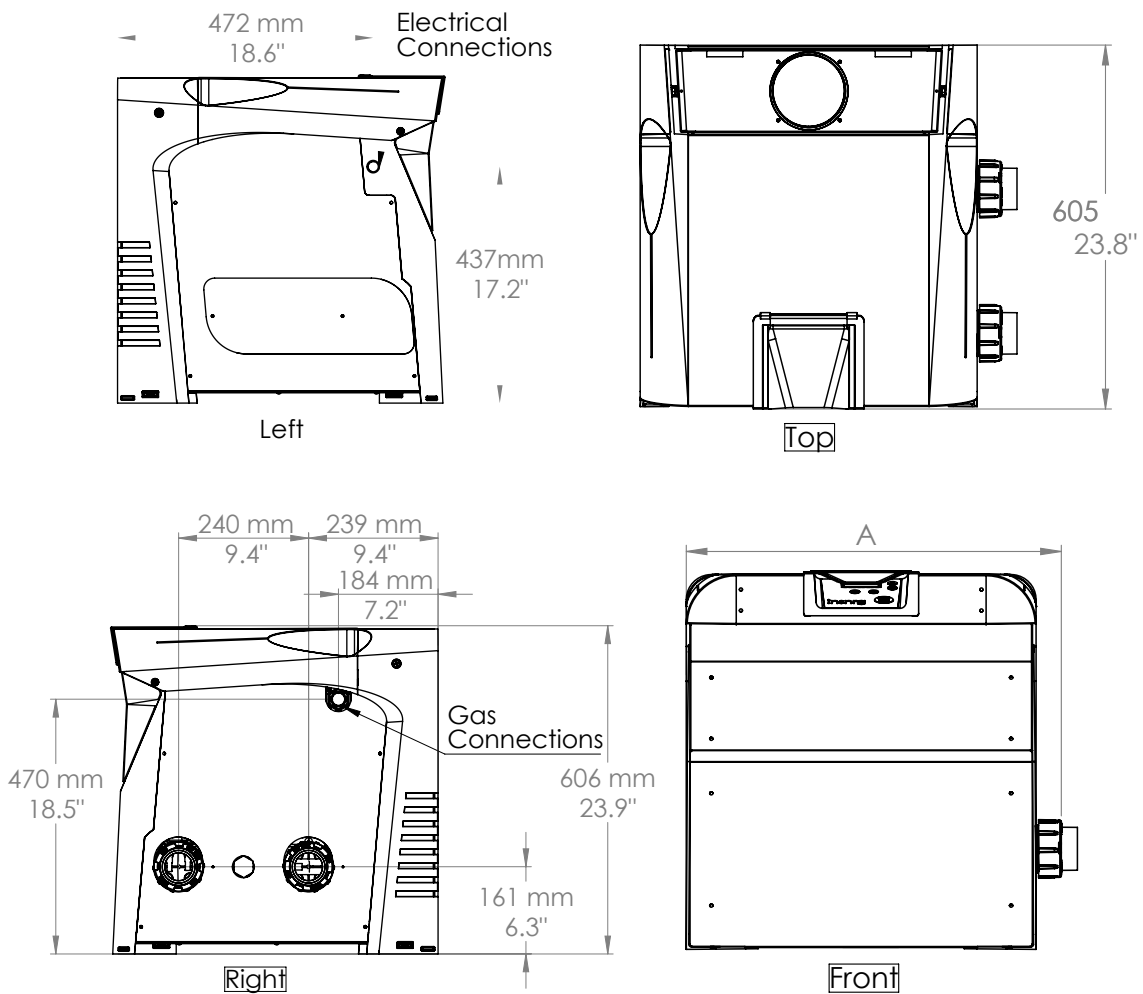

RELAX, YOU'RE COVERED (WARRANTY SUPPORT)

Your G9 Gas Heater comes complete with a limited 3 year warranty. Refer to owners manual at www.insnrg.com for full warranty details.

AFTER SALES SUPPORT

Talk to a real person for real advice and be assured our in house in field Service Technicians are the best trained in the industry.

WANT MORE INFORMATION? CONTACT INSNRG ON 1 800 467 674